

Product range

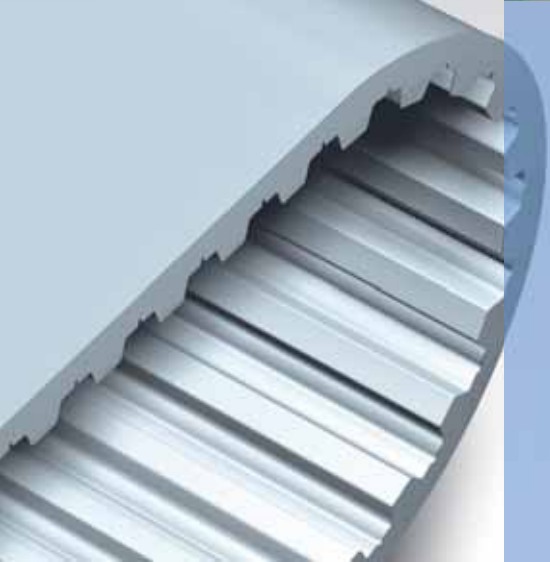
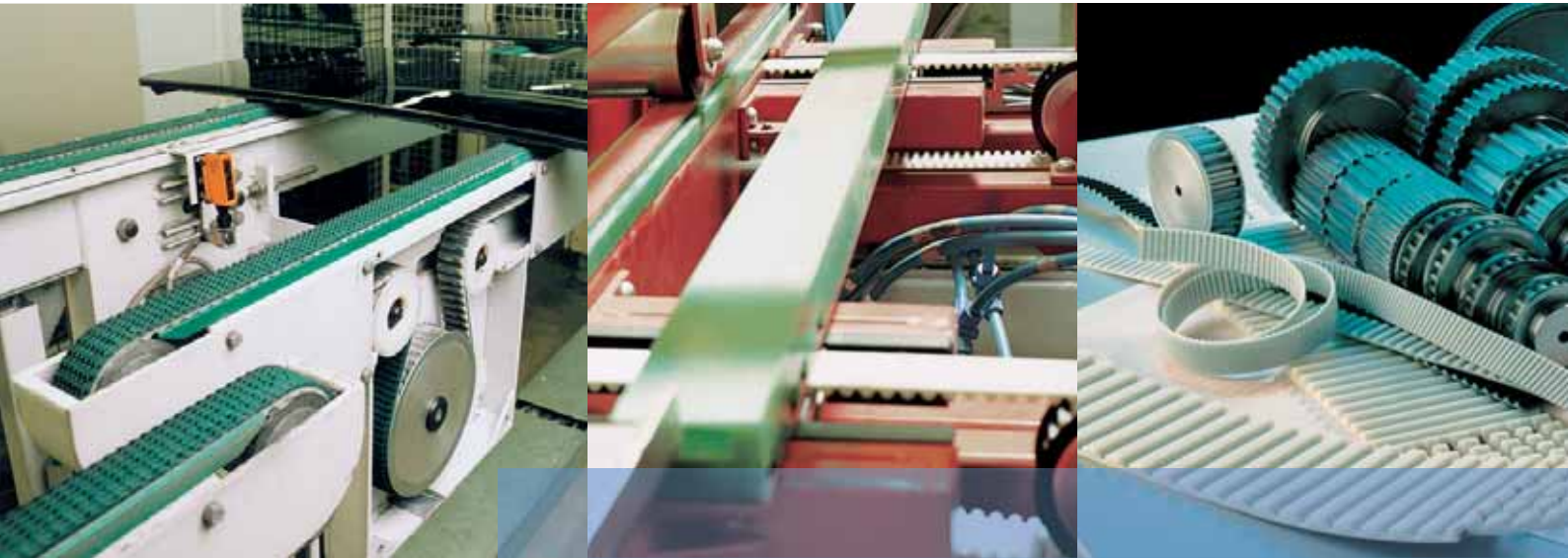

siegling proposition
timing belts

siegling proposition

timing belts

In modern power transmission and handling technology, the timing belt is often a key machine element with numerous and varied applications. At the same time, timing belts are exceptionally economical and reliable.

Siegling Proposition high-efficiency timing belts are constructed of high-quality polyurethane with an embedded tension member of steel wires. Light weight and of extremely high tensile strength, they are low noise in operation, require practically no maintenance and experience very little wear and tear. These characteristics mean timing belts are suitable for demanding applications with extreme acceleration and braking processes, as well as for precise positioning.

The standard Siegling Proposition types can be modified for various tasks for power transmission, positioning, conveying, synchronizing, or interval conveying and singling.

Modifications include the application of coatings, coverings and textures, the welding on of the most varied of profiles, and special processing such as perforating, milling and grinding.

As form-fit power transmission and conveying elements, Siegling Proposition timing belts round off the family of tried-and-tested Siegling Transilon conveyor and processing belts. Our extensive experience in the field of light materials handling is your guarantee for excellent product quality, sound consulting and speedy service.

The properties

wear-resistant

maintenance-free

good tracking properties

low noise

flexible

saves room

The advantages

▶ long belt life

▶ no maintenance costs

▶ reliable, gentle operation

▶ safe working conditions

▶ small reversing diameters,
high counter-bending strength

▶ compact machine designs possible

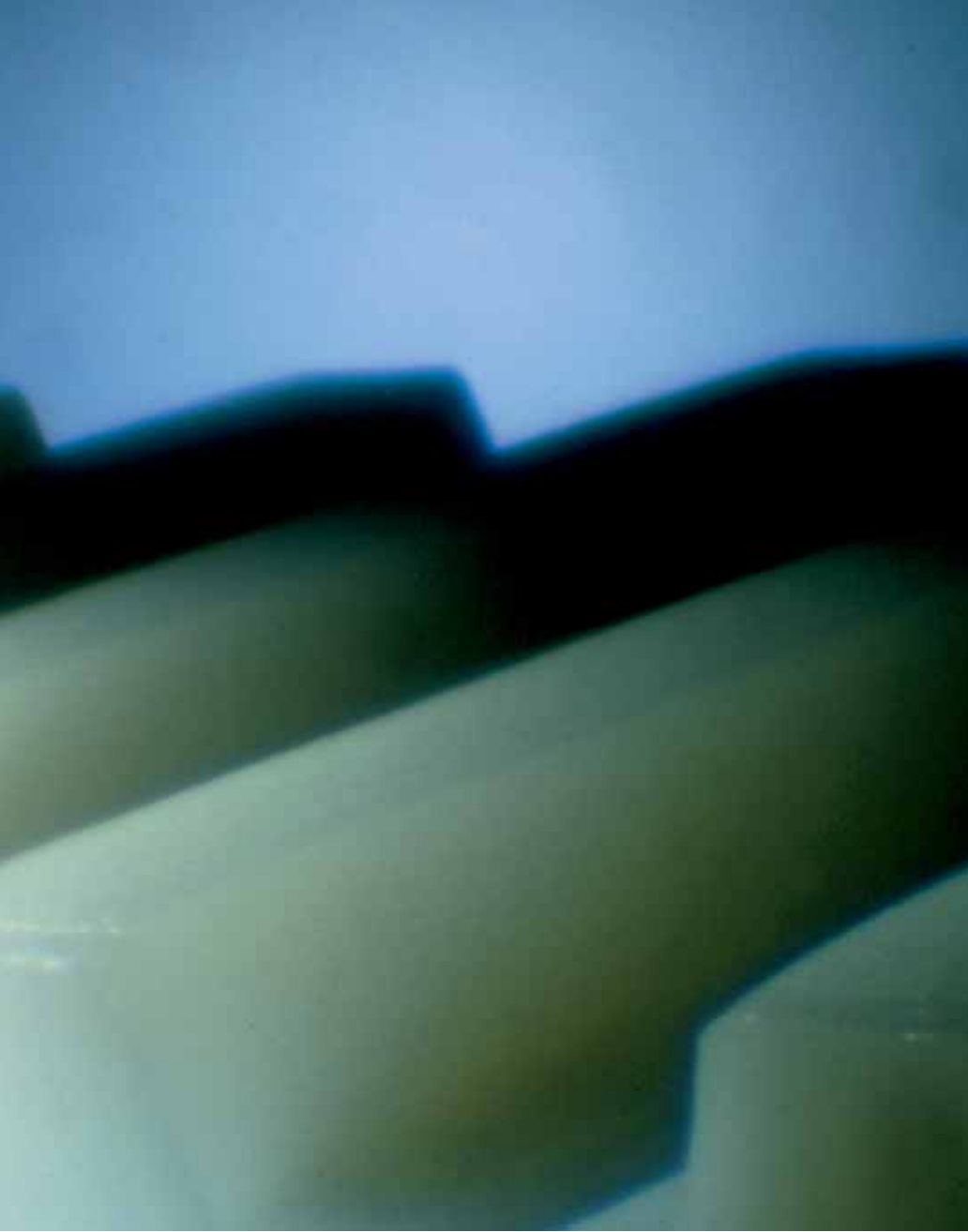

Contents

The application of Siegling Proposition	4
Standard product range	6
Coatings and coverings	10
Cams	12
Customized products	14
Accessories	16
Chemical resistance	18
Splicing procedure/ on-site fitting	19

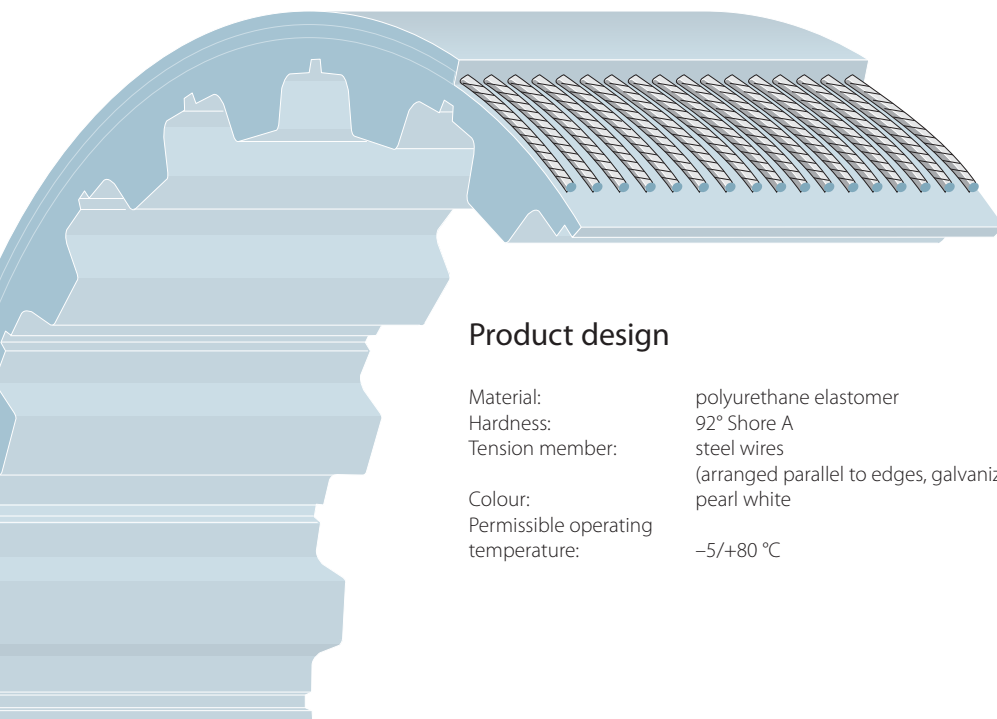

Product design

Material:	polyurethane elastomer
Hardness:	92° Shore A
Tension member:	steel wires (arranged parallel to edges, galvanized)
Colour:	pearl white
Permissible operating temperature:	-5/+80 °C



MOVEMENT SYSTEMS

The application of Siegling Proposition

Linear drives

Thanks to form-fit transmission and narrow fabrication tolerances, Siegling Proposition timing belts guarantee isogonic rotations and high repeating accuracy in linear drives.



Siegling Proposition on the power test rig.

Automation and handling technology

In automation and handling technology, they are often used in place of chains and other systems which require complex designs.



Conveying of cigarette packs on their way to packaging.

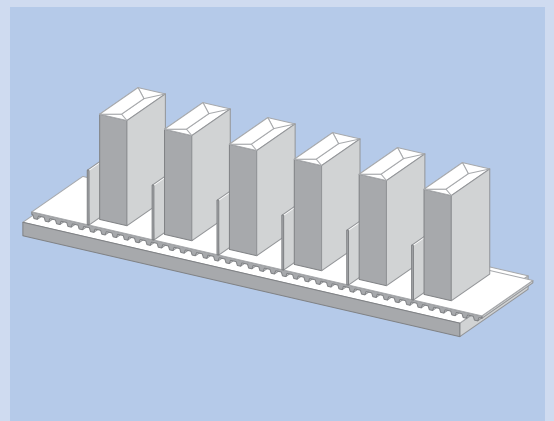
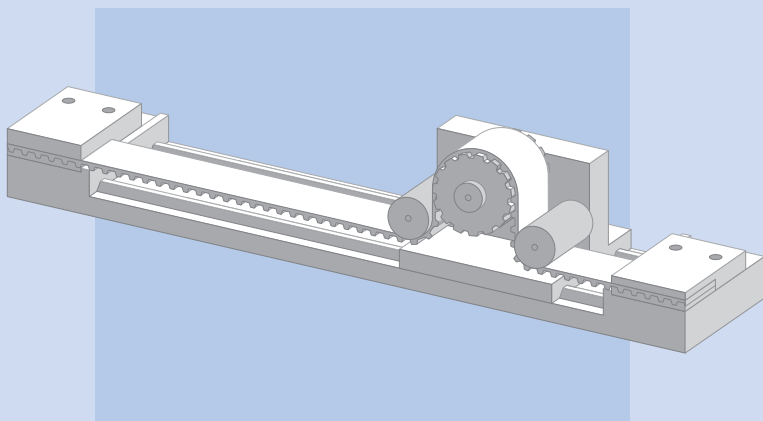

Lifting devices, portal robots and roll-up door drives

In lifting devices, portal robots and roll-up door drives, they transmit large forces while providing a high degree of positioning accuracy.



Siegling Proposition timing belts in the vertical axis of an industrial robot.

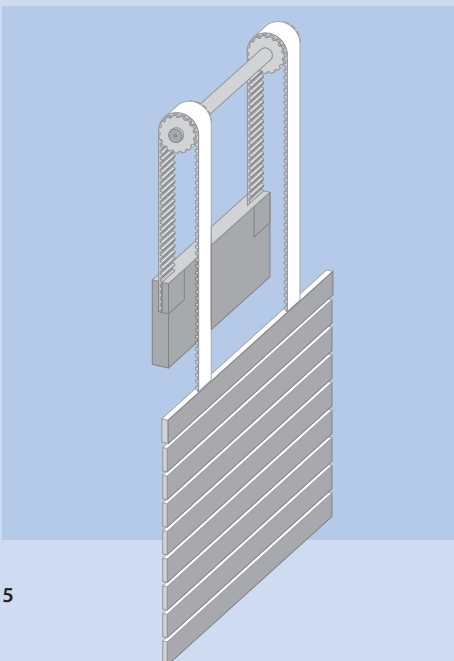

Synchronous operation

As conveyor belts running synchronously in sets, they guarantee that the goods being conveyed remain in position. Cams, coatings and coverings make it possible to “customize” the belts precisely for the goods being conveyed and the conveying task.



Conveying of car windows by belts running synchronously. The coverings on the reverse face of the timing belts treat the goods gently and improve the grip properties.

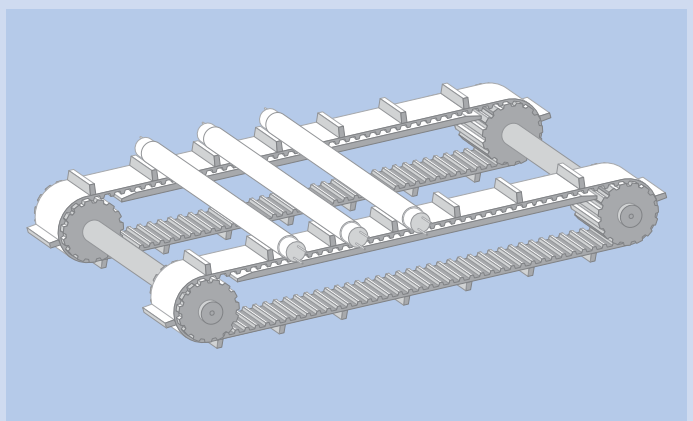

Standard product range

T and AT types

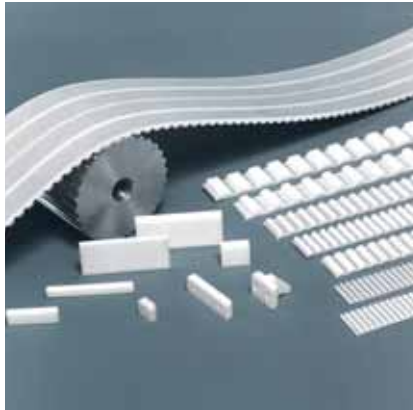

General technical data

Width [mm]	Width tolerance [mm]	Weight, approx. [kg/m]	Z _{min} minimum number of teeth	d _{min} approx. [mm] tensioning roller on toothed face	d _{min} approx. [mm] tensioning roller on reverse face of belt	Permissible operating temperature [°C]
------------	----------------------	------------------------	--	---	---	--

T 5

T 5, T 5 PAZ, T 5 PAZ/PAR

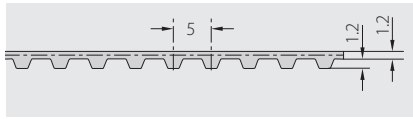

10	±0.5	0.024	14	30	30	-5/+80
16	±0.5	0.038	14	30	30	-5/+80
25	±0.5	0.060	14	30	30	-5/+80
32	±0.5	0.077	14	30	30	-5/+80
50	±0.5	0.120	14	30	30	-5/+80

T 10

T 10, T 10 PAZ, T 10 PAZ/PAR

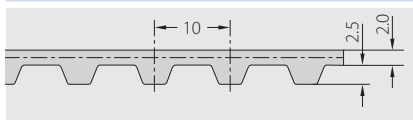

16	±0.5	0.077	16	60	60	-5/+80
25	±0.5	0.120	16	60	60	-5/+80
32	±0.5	0.154	16	60	60	-5/+80
50	±0.5	0.240	16	60	60	-5/+80
75	±0.5	0.360	16	60	60	-5/+80
100	±0.5	0.480	16	60	60	-5/+80

T 20

T 20, T 20 PAZ

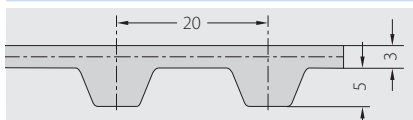

25	±1.0	0.193	16	120	120	-5/+80
32	±1.0	0.246	16	120	120	-5/+80
50	±1.0	0.385	16	120	120	-5/+80
75	±1.0	0.577	16	120	120	-5/+80
100	±1.0	0.770	16	120	120	-5/+80

AT 5

AT 5, AT 5 PAZ, AT 5 PAZ/PAR

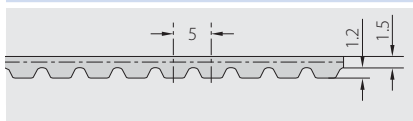

10	±0.5	0.030	14	25	45	-5/+80
16	±0.5	0.048	14	25	45	-5/+80
25	±0.5	0.075	14	25	45	-5/+80
32	±0.5	0.096	14	25	45	-5/+80
50	±0.5	0.150	14	25	45	-5/+80

AT 10

AT 10, AT 10 PAZ, AT 10 PAZ/PAR

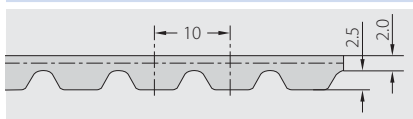

25	±0.5	0.160	16	50	120	-5/+80
32	±0.5	0.205	16	50	120	-5/+80
50	±0.5	0.320	16	50	120	-5/+80
75	±0.5	0.480	16	50	120	-5/+80
100	±0.5	0.640	16	50	120	-5/+80

AT 20

AT 20, AT 20 PAZ, AT 20 PAZ/PAR

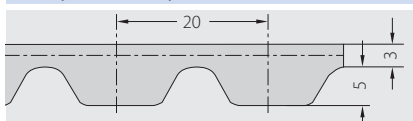

25	±1.0	0.250	18	120	180	-5/+80
32	±1.0	0.320	18	120	180	-5/+80
50	±1.0	0.500	18	120	180	-5/+80
75	±1.0	0.750	18	120	180	-5/+80
100	±1.0	1.000	18	120	180	-5/+80

Drawings are at a scale of 1:1

Open belts



Endless welded belts

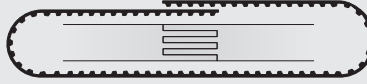

siegling proposition
timing belts

F_{perm} [N]	Clamping length [mm]	Standard roller length [m]	F_{perm} [N]	Min. production length [mm]	Standard roller length [m]
390	40.7	100	190	710	100
550	40.7	100	270	710	100
910	40.7	100	450	710	100
1100	40.7	100	550	710	100
1690	40.7	100	840	710	100
1310	80	100	650	720	100
2200	80	100	1100	720	100
2620	80	100	1300	720	100
4200	80	100	2100	720	100
5100	80	100	2550	720	100
7100	80	100	3550	720	100
3200	160	80	1600	800	80
4100	160	80	2050	800	80
6500	160	80	3250	800	80
9800	160	80	4900	800	80
13500	160	80	6700	800	80
560	40.7	100	280	710	100
1260	40.7	100	630	710	100
1680	40.7	100	840	710	100
2240	40.7	100	1100	710	100
3500	40.7	100	1750	710	100
3750	80	100	1850	720	100
5000	80	100	2500	720	100
7500	80	100	3700	720	100
12000	80	100	6000	720	100
16000	80	100	8000	720	100
5800	160	80	2900	800	80
7200	160	80	3600	800	80
11700	160	80	5800	800	80
18000	160	80	9000	800	80
25200	160	80	12000	800	80

Pearl white is the standard colour of the timing belts. Special colours can be produced on request.

Truly endless timing belts available on request.

The values stated refer to room temperature.

Designations for ordering can be found on the following 2 pages.



Standard product range L, H, HTD types

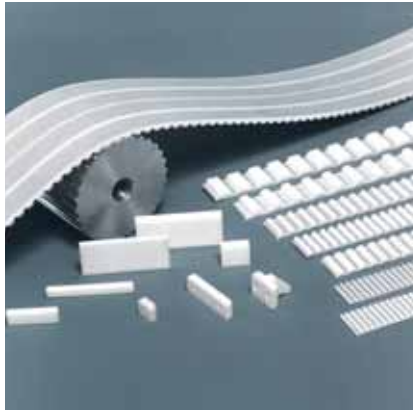

General technical data

Width [mm]	Width tolerance [mm]	Weight, approx. [kg/m]	Z _{min} minimum number of teeth	d _{min} approx. [mm] tensioning roller on toothed face	d _{min} approx. [mm] tensioning roller on reverse face of belt	Permissible operating temperature [°C]
------------	----------------------	------------------------	--	---	---	--

L

L

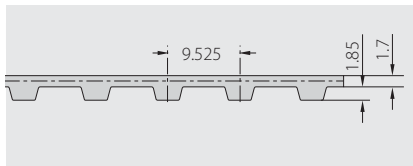

12.7	±0.5	0.050	16	50	50	-5/+80
19.1	±0.5	0.074	16	50	50	-5/+80
25.4	±0.5	0.099	16	50	50	-5/+80
38.1	±0.5	0.149	16	50	50	-5/+80
50.8	±0.5	0.198	16	50	50	-5/+80
76.2	±0.5	0.297	16	50	50	-5/+80
101.6	±0.5	0.396	16	50	50	-5/+80

H

H

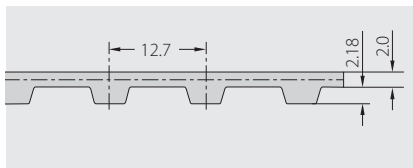

12.7	±0.5	0.057	14	80	80	-5/+80
19.1	±0.5	0.086	14	80	80	-5/+80
25.4	±0.5	0.114	14	80	80	-5/+80
38.1	±0.5	0.171	14	80	80	-5/+80
50.8	±0.5	0.229	14	80	80	-5/+80
76.2	±0.5	0.343	14	80	80	-5/+80
101.6	±0.5	0.457	14	80	80	-5/+80

HTD 8 M

HTD 8 M, HTD 8 M PAZ

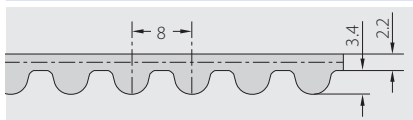

20	±0.5	0.132	20	50	120	-5/+80
30	±0.5	0.198	20	50	120	-5/+80
50	±0.5	0.330	20	50	120	-5/+80
85	±0.5	0.561	20	50	120	-5/+80

HTD 14 M

HTD 14 M

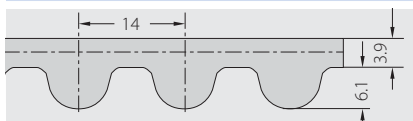

40	±1.0	0.440	25	120	180	-5/+80
55	±1.0	0.605	25	120	180	-5/+80
85	±1.0	0.935	25	120	180	-5/+80
115	±1.0	1.265	25	120	180	-5/+80

Drawings are at a scale of 1:1

Designations for ordering timing belts sized metrically

	25	T 10	2500	09-MV	with U 20 coating on reverse side
Width [mm]	25	25	2500	25	25
Type/pitch	T 10	T 10	T 10	T 10	T 10
Length [mm]	2500	2500	2500	2500	2500
Type of splice*	09-MV	09-MV	09-MV	09-MV	09-MV
Additional designation	with U 20 coating on reverse side	with U 20 coating on reverse side	with U 20 coating on reverse side	with U 20 coating on reverse side	with U 20 coating on reverse side

* 07 = open, 03 = prepared for meander splice
09-MV = welded endless (meander splice)

Open belts



Endless welded belts

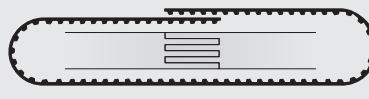

siegling proposition
timing belts

F_{perm} [N]	Clamping length [mm]	Standard roller length [m]	F_{perm} [N]	Min. production length [mm]	Standard roller length [m]
890	76.5	100	440	720	100
1340	76.5	100	650	720	100
1780	76.5	100	870	720	100
2670	76.5	100	1310	720	100
3560	76.5	100	1760	720	100
5100	76.5	100	2550	720	100
6600	76.5	100	3300	720	100
890	104.3	100	440	720	100
1340	104.3	100	650	720	100
1780	104.3	100	870	720	100
2670	104.3	100	1310	720	100
3560	104.3	100	1760	720	100
5100	104.3	100	2550	720	100
6600	104.3	100	3300	720	100
2800	65	100	1400	920	100
4200	65	100	2100	920	100
7000	65	100	3500	920	100
11500	65	100	5700	920	100
8500	114	80	4200	952	80
11800	114	80	5800	952	80
19500	114	80	9600	952	80
23600	114	80	11600	952	80

Pearl white is the standard colour of the timing belts. Special colours can be produced on request.
Truly endless timing belts available on request.
The values stated refer to room temperature.

Designations for ordering timing belts sized in inches

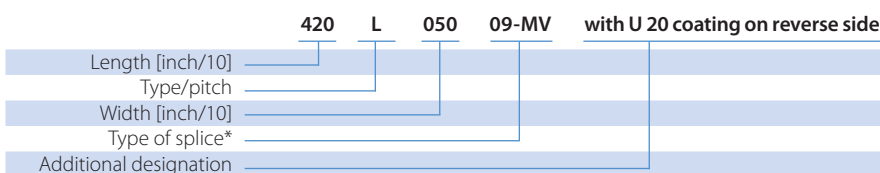

* 07 = open, 03 = prepared for meander splice
09-MV = welded endless (meander splice)



MOVEMENT SYSTEMS

Coatings and coverings

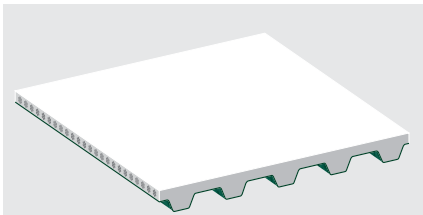

PAZ

Material: polyamide fabric (toothed face)
 Characteristic/
 application: low drag, protects against wear, reduces noise

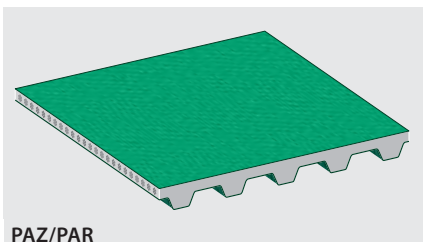

PAZ/PAR

Material: polyamide fabric (on both faces)
 Characteristic/
 application: low drag, protects against wear, reduces noise

For the types PAZ and PAZ/PAR (above), the polyamide fabric is applied during the production of the timing belt. Therefore their sizes correspond to those of the standard types.

All standard Siegling Proposition types can be equipped with various coatings or coverings to optimize their suitability for the individual applications.

On the toothed and/or reverse face, coverings of polyester fabric reduce the drag. This facilitates the intermeshing of the teeth, in turn reducing the noise.

Other coverings and coatings for the reverse face, varying in material and texture considerably,

- increase the drag, thereby improving the grip properties (pick-off belts, inclined conveyors)
- conform to FDA regulations (processing of food)
- protect the surface of sensitive goods (glass, furniture)
- are largely unaffected by rough goods or goods with sharp edges thanks to their tenacity (sheet metal, wood).

Coating type/Colour		
1	Linatrilite	orange
2	Linatex	red
3	Linafood	white
4	U-20	transp.
	U-30	transp.
	U-40	transp.
5	U-20 LG	transp.
6	G/NSTR	light green
7	G/GSTR	green
8	G/AR	black
9	V/20	white
10	V/20/FG	white
11	SZ	black
12	SO	orange
13	PU	yellow
14	Sylomer	green
15	Vulcocell VS 40 MH	yellow
16	Novo 12 HC	grey
17	Novo 25 NA	light grey
18	Silicone	transp.
19	Leather	grey

- 4 U-30 transparent
- 5 U-20 LG transparent
- 6 G/NSTR light green
- 7 G/GSTR green

- 1 Linatrilite orange
- 2 Linatex red
- 3 Linafood white

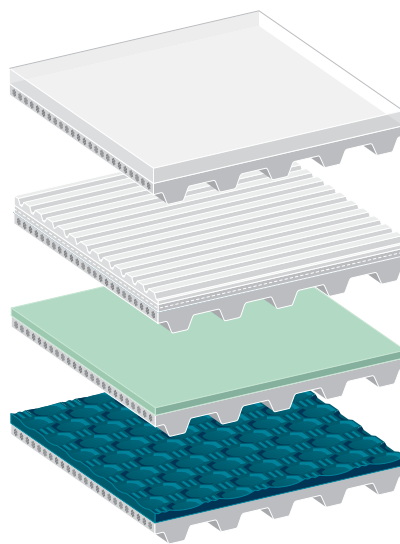
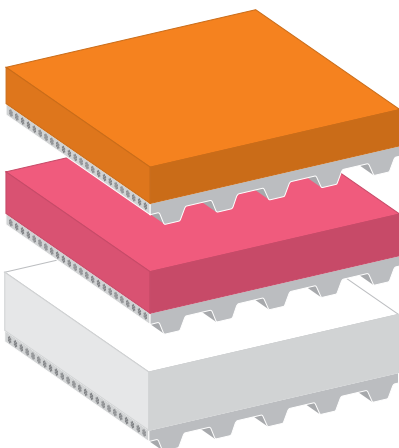

- 8 G/AR black
- 9 V/20 white
- 10 V/20/FG white

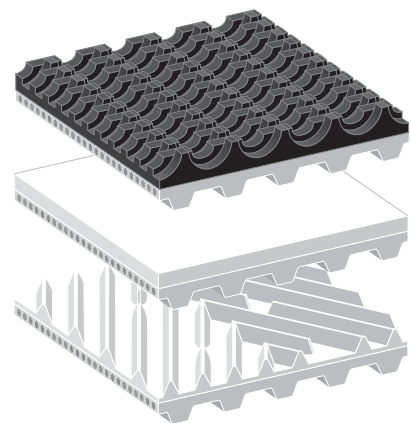

Coating material	Hardness [Shore A]	Thickness [mm]	Thickness tolerance [mm]	d _{min} approx. [mm]	Permissible operating temperature [°C]	Resistance	Applications	Properties
Nitrile (NBR)	55	2/3	±0.2 5/6 8/10	40	-20/+110 75 125	Simple fats and oils	Wood conveying Chemical & oil contact conveying	High friction and wear resistance
Natural Rubber	38	2/3 5/6 8/10	±0.2	40 50 80	-40/+70	Wet abrasion	Paper & wood conveying industry, paper conveying	High friction and abrasion resistance; high flexibility at low temperatures
Natural Rubber	38	6-8	±0.2	65	-40/+70	Wet abrasion	Food and pharmaceutical industries, paper conveying	FDA approval for direct contact with food
Polyurethane	87	2 3 4	±0.2	50 75 100	-20/+50	Simple fats and oils	Conveying of abrasive parts	Cut resistant extr. abrasion resistant
Polyurethane	87	2	±0.2	50	-20/+50	Simple fats and oils	Conveying of abrasive parts	Cut resistant extr. abrasion resistant
Rubber	60	0.9	±0.2	40	-20/+100	Simple fats and oils	General conveying	Good wear resistance
Rubber	50	2.6	±0.5	60	-20/+100	Simple fats and oils	Conveying steel plates, wood, paper etc.	Good grip, wear resistance
Rubber	50	4	±0.5	50	-20/+100	Simple fats and oils	General conveying, inclined conveying	Good grip
PVC	60	2	±0.2	50	-10/+70	Acids, salts & bases	Food and pharmaceutical industries	FDA approval for direct contact with food
PVC	60	3-4	±0.5	60	-10/+70	Acids, salts & bases	Food and pharmaceutical industries, glass conveying	FDA approval for direct contact with food
Neoprene rubber	165-205 kg/m ³	5 10 15	±1.0	40 65 90	-20/+100	Simple fats and oils	Conveying of delicate parts	Flexible, compressible
Rubber	160 kg/m ³	10 15 20	±1.0	65 90 120	-20/+80	No fats and oils	Conveying of delicate parts	Flexible, extremely compressible
Polyurethane foam	55	2/3/4	±0.2	50	-10/+60	Simple fats and oils	Vacuum & paper applications	Good wear resistance
Polyurethane foam	300 kg/m ³	5/6 8 10/12	±1.0	50 65 90	-30/+70	Simple fats and oils	Conveying of delicate parts	Flexible, compressible
Polyurethane foam	400 kg/m ³	4	±0.5	60	-30/+80	Simple fats and oils	Conveying of delicate parts	Flexible, compressible
Polyester fleece	-	1.2	±0.5	50	-10/+120	Simple fats and oils	General conveying, glass conveying	Antistatic
Polyester fleece	-	2.5	±0.5	60	-10/+120	Simple fats and oils	General conveying, glass conveying	Low friction
Silicone	30	1	±0.5	50	-20/+100	Simple fats and oils	Conveying hot and sticky goods	Good grip
Leather	-	2-3	±1.0	60	0/+60	Simple fats and oils	Conveying of oily, greasy parts	Good grip

- 11 SZ black
- 12 SO orange
- 13 PU yellow

- 14 Sylomer green
- 15 Vulcocell yellow
- 16 Novo 12 HC grey

- 17 Novo 25 NA light grey
- 18 Silicone transparent
- 19 Leather grey

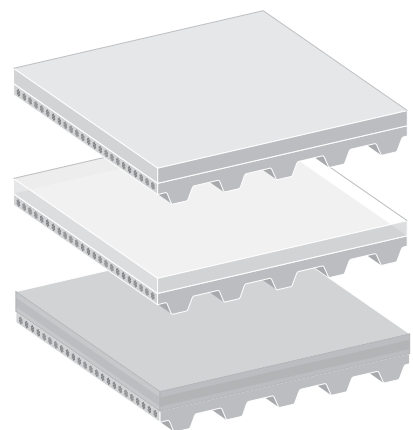
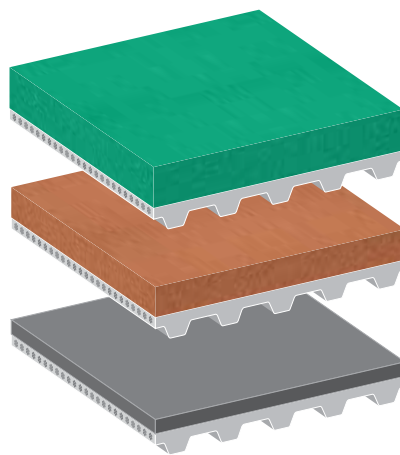
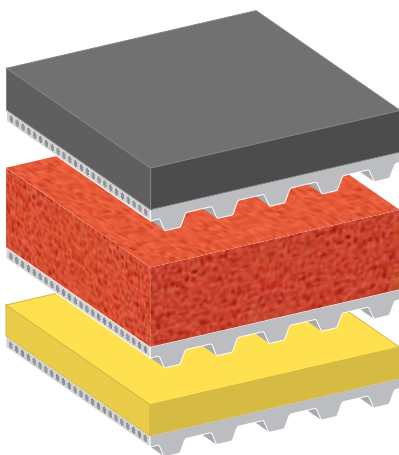

Cams

For conveying and many more specialized tasks in material handling (interval conveying, singling, positioning), cams pave the way for innovative design solutions. Cams are made of polyurethane – as are the timing belts themselves, ensuring the reliability of the weld between the cam and the reverse face of the timing belt.

For special requirements, Forbo Siegling also produce customized cams as injection moulded parts or from half-finished products.

Lead time required for customized cams is approx. four weeks. A large number of the profiles for Siegling Transilon conveyor and processing belts can also be used for Siegling Proposition timing belts see brochure Siegling Transilon – Technical information 2 (Special features and properties) ref. no. 318.

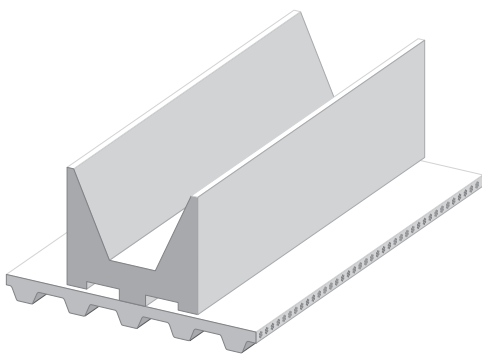
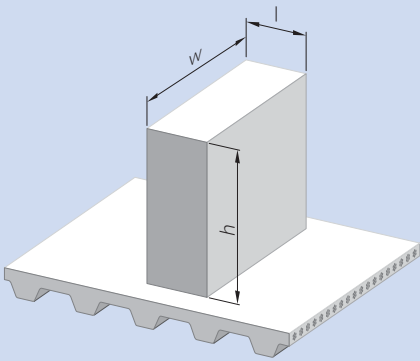

CAM 3101 (lwxh)
Main dimensions [mm]: 19 x 60 x 16

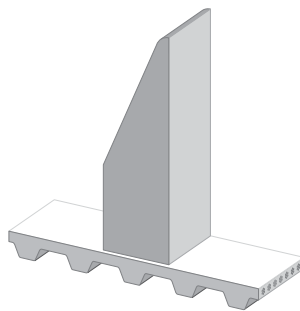

CAM 3102 (lwxh)
Main dimensions [mm]: 10 x 11 x 30

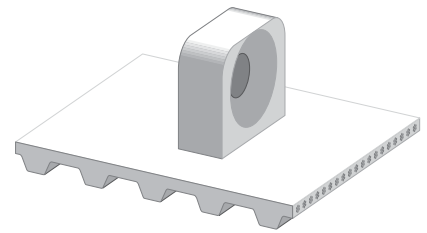

CAM 3001 (lwxh)
Main dimensions [mm]: 6 x 15 x 14,5

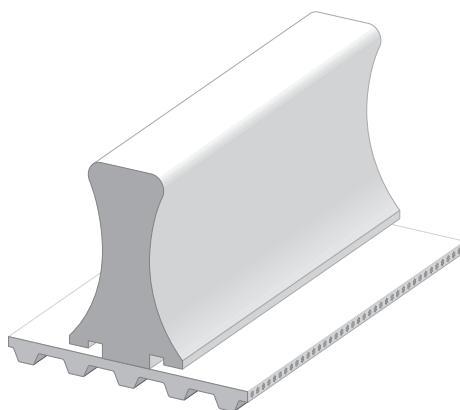

CAM 3103 (lwxh)
Main dimensions [mm]: 18 x 40 x 27

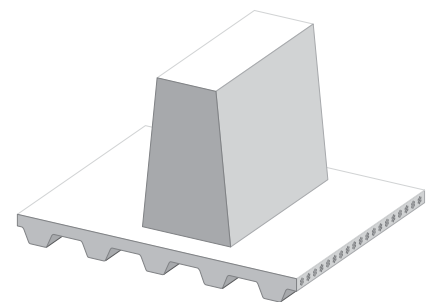

CAM 1010 (lwxh)
Main dimensions [mm]: 12 x 23 x 18



CAM 3100 (lwxh)
Main dimensions [mm]: 38 x 100 x 100

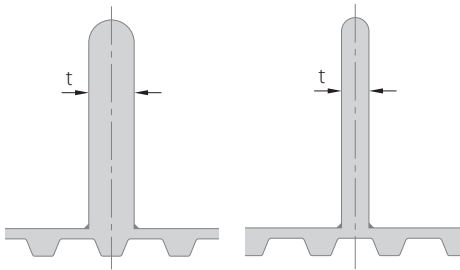

Welding of cams

The welding of cams onto a timing belt affects its flexibility. The smallest possible cam thickness (t) should be selected. If possible, cams should be attached "opposite teeth".

Cams can be welded onto the belt very close to each other. The best distance between cams (but not absolutely necessary) is a multiple of the timing belt pitch. The positioning precision here is ± 0.25 mm for the cam centre distance.

In these tables, the recommended maximum cam thickness (t) is listed according to the number of teeth on the sprocket.

Maximum cam thickness in mm when welded on opposite tooth

Number of teeth on sprocket

Type	20	25	30	40	50	60	100
T 5	5	6	6	8	9	10	12
T 10	8	9	10	12	14	15	20
T 20	12	13	15	18	20	23	30
AT 5	5	6	6	8	9	10	12
AT 10	8	9	10	12	14	15	20
AT 20	12	13	15	18	20	23	30
L	6	7	8	10	12	13	16
H	8	9	10	12	14	15	20
HDT 8 M	6	8	9	10	12	14	15
HDT 14 M	-	10	12	13	15	18	20

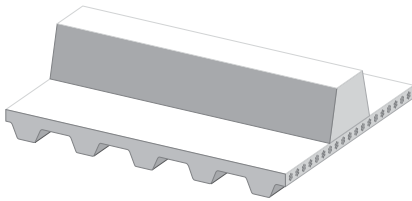

K Profile

Main dimensions: see table on page 15

Maximum cam thickness in mm when welded on opposite gap between teeth

Number of teeth on sprocket

Type	20	25	30	40	50	60	100
T 5	2	2	3	4	6	8	10
T 10	3	4	4	6	9	12	20
T 20	5	5	6	8	12	20	30
AT 5	2	2	3	4	6	8	10
AT 10	3	4	4	6	9	12	20
AT 20	5	5	6	8	12	20	30
L	3	3	4	5	7	10	16
H	4	5	6	7	10	12	20
HDT 8 M	3	3	4	4	6	9	12
HDT 14 M	-	5	6	6	7	10	13

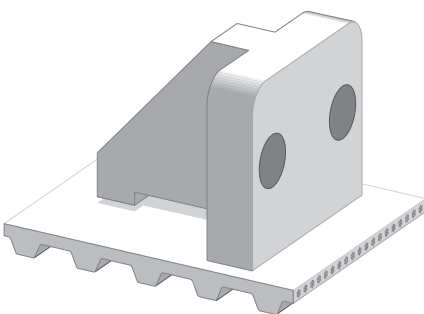

CAM 3003 (l_xw_xh)
Main dimensions [mm]: 26 x 25 x 20

Customized products

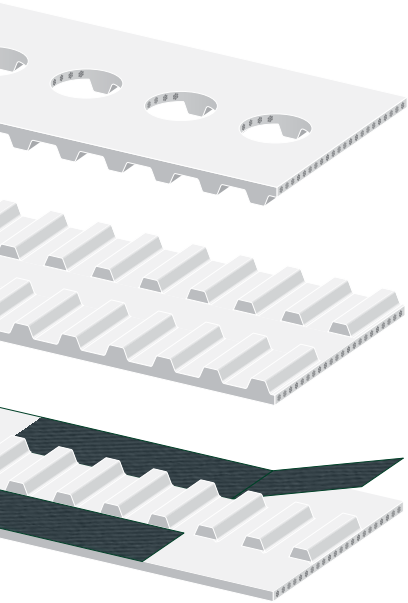

By modifying timing belts with and without coatings or coverings afterwards, it is possible to tailor them exactly to meet the needs of individual applications in materials handling. Because of the wide array of possibilities and combinations, we can show you here just a very small selection. Please contact your Forbo Siegling partner regarding any specific requirements you may have.

Mechanical processing

Almost any shape can be milled, ground or punch-cut into timing belts and coatings or coverings with very narrow tolerances.

Special coatings and coverings

It is possible to apply an extra covering of PA fabric afterwards – also to sections which have been milled – to improve the low grip properties.

Special colours

Timing belts (as well as cams) can be produced in special colours.

Helically-wound endless belts

Information about helically-wound endless belts is available on request.

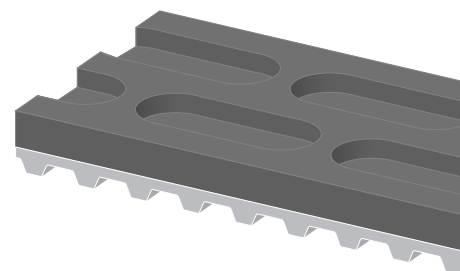
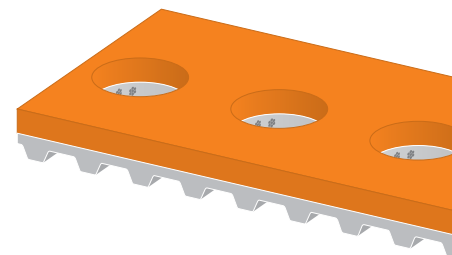
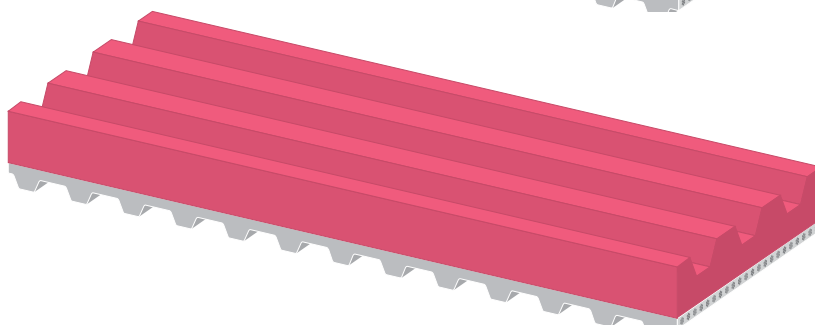
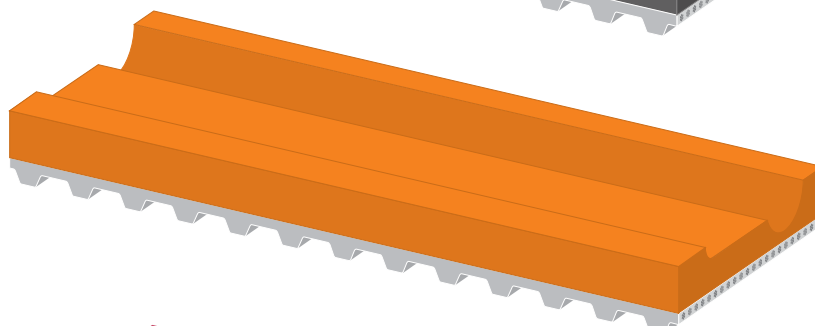
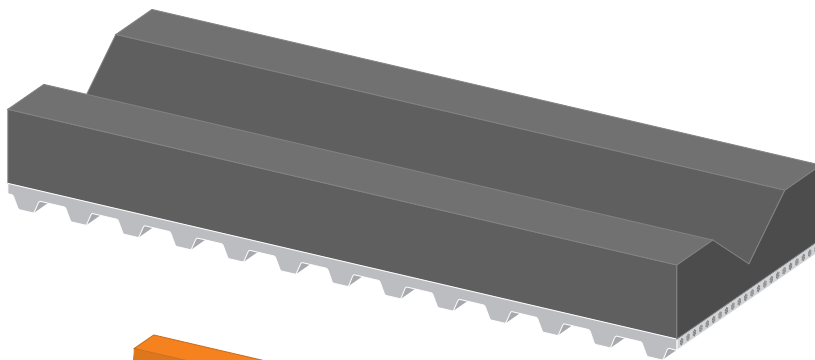

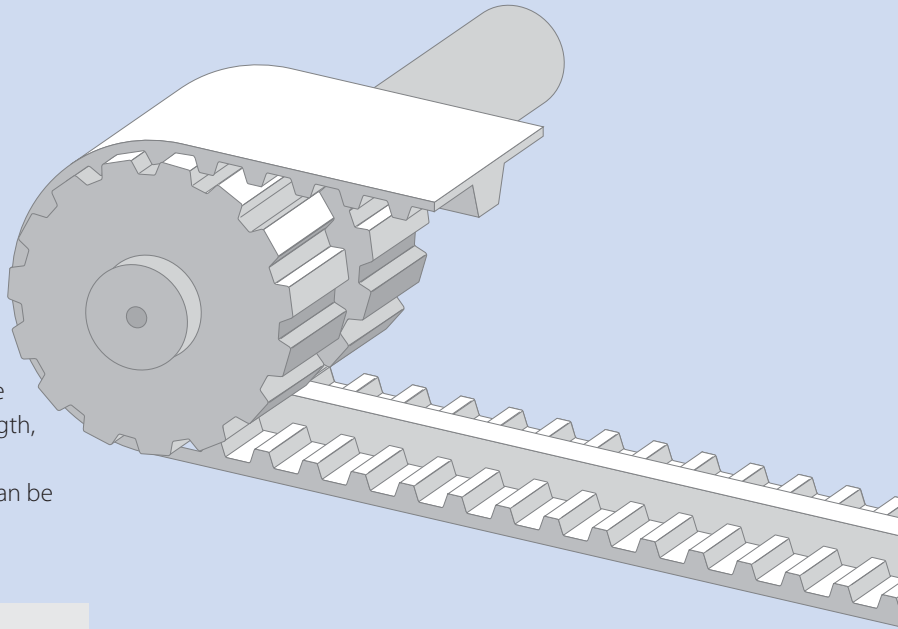

Timing belts with longitudinal tracking profiles

The wedge profiles mounted on the timing belts ensure that the belts track perfectly straight over the entire length, even where lateral forces are a factor. Flanged pulleys are not required. All timing belt types can be equipped with various wedge profiles.

Longitudinal tracking profiles

Type	Material	Colour	w x h x s [mm]	Hardness [Shore A]	Groove with A [mm]	d _{min} [mm]
K 6-U65	Urethane	transparent	6 x 4 x 4	65	7	40
K 10-U65	Urethane	transparent	10 x 6 x 6	65	11	70
K 13-U65	Urethane	transparent	13 x 8 x 7,5	65	14	100
K 15-U65	Urethane	transparent	15 x 8 x 9,5	65	16	100
K 17-U65	Urethane	transparent	17 x 11 x 9,5	65	18	100

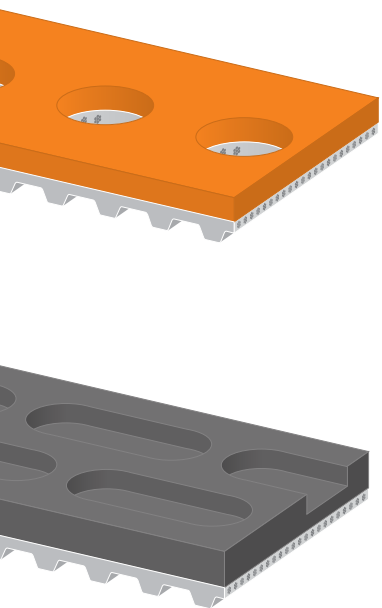
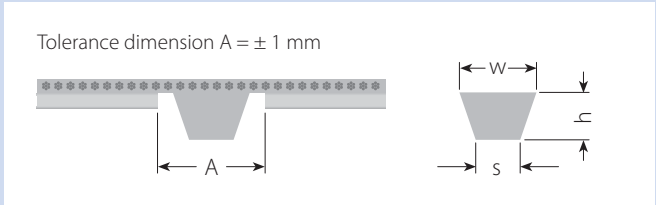

Powerbelt

For the transmission of large tensile forces, the Forbo Siegling Powerbelt is an alternative to cables, chains and fabric belts.

Material:	polyurethane elastomer
Hardness:	92° Shore A
Tension member:	steel wires (arranged parallel to edges, galvanized)
Colour:	black
Permissible operating temperature:	-5/+80 °C

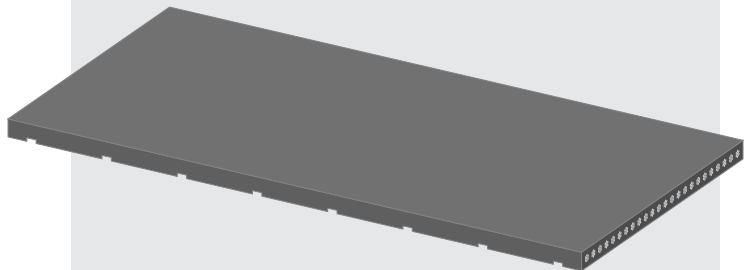

Forbo Siegling Powerbelt was developed especially for use in sports and fitness equipment, roll-up doors and venetian blinds. It is available only as open material.

Data sheet available on request.

Accessories



Toothed pulleys for timing belts

For the service life of the timing belt and for smooth operations, it is vital that the toothed pulley be matched correctly to the timing belt.

For all timing belts in its product range, Forbo Siegling carries the corresponding toothed pulley.

- Standard design with boring
- Special methods of attachment on request
- 0 pulleys and SE pulleys available on request
- Can be fabricated from drawing

Standard material for general applications is aluminium. For higher loads, steel pulleys are recommended. Toothed pulleys are available on request.

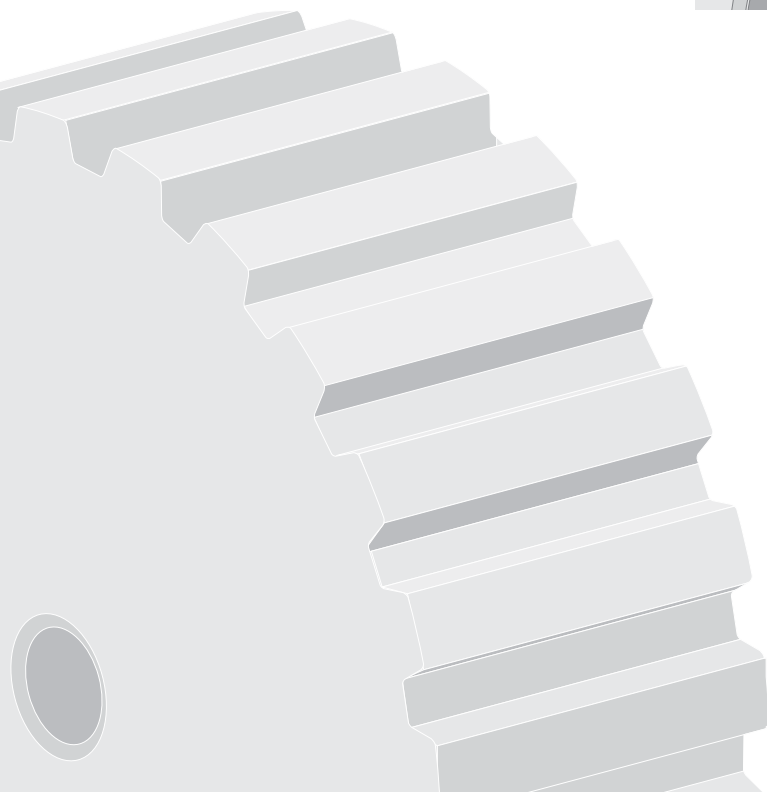
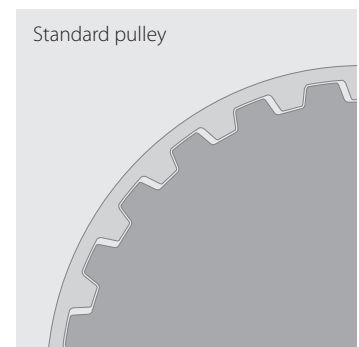
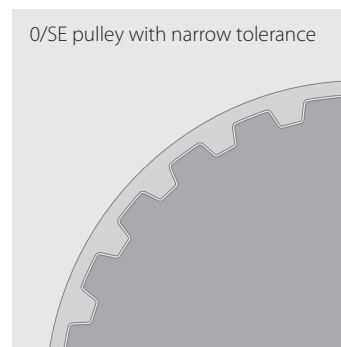

Clamping plates

Clamping plates for fastening open material are available for all timing belt types and in all standard sizes.

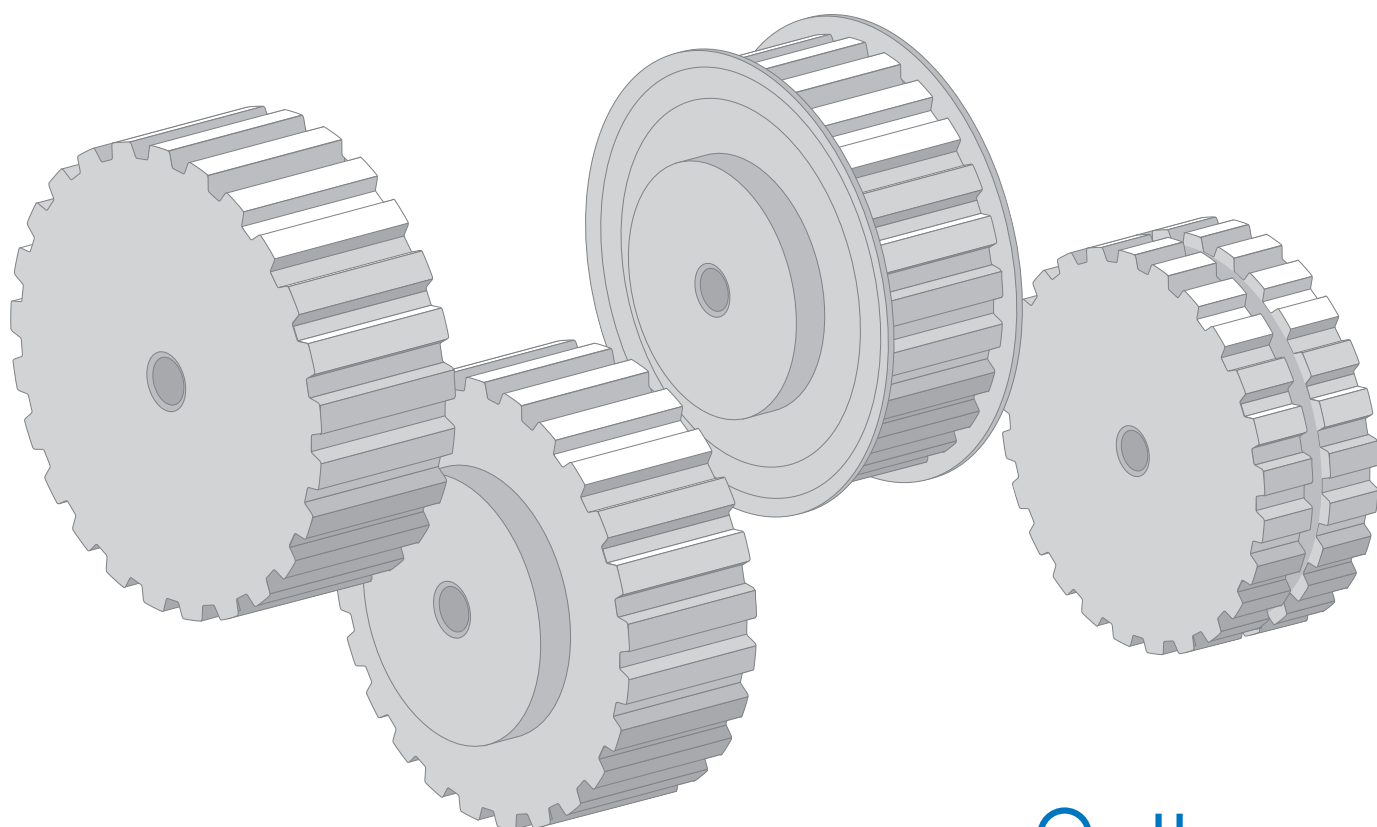
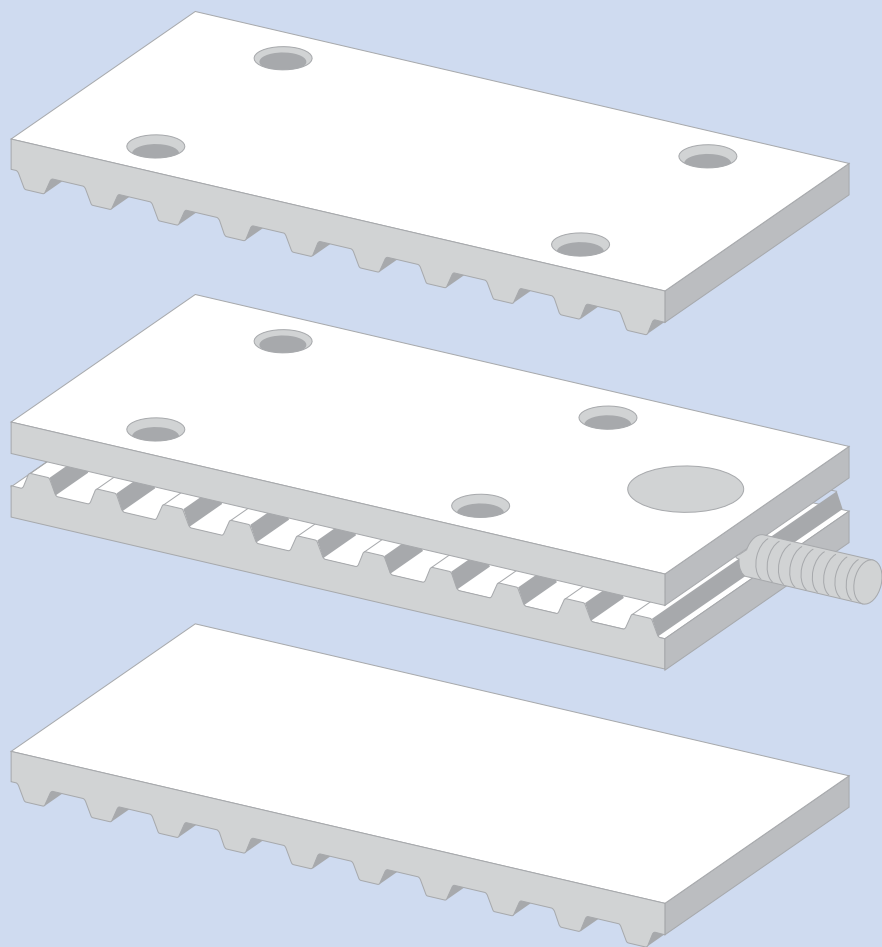

forbo

MOVEMENT SYSTEMS

Resistances

Chemical	Resistance
Acetic acid 20%	○
Acetone	○
Aluminium chloride, aqueous 5%	●
Ammonia 10%	●
Aniline	–
ASTM oil 1	●
ASTM oil 2	●
ASTM oil 3	○
Benzol	○
Butyl acetate	–
Butyl alcohol	○
Carbon tetrachloride	–
Common salt solution, conc.	●
Cyclohexanol	○
Diesel oil	●
Dimethyl formamide	–
Ethyl acetate	–
Ethyl alcohol	○
Ethyl ether	●
Hydrochloric acid 20%	○
Iron chloride, aqueous 5%	○
Isopropyl alcohol	○
Kerosine	●
Lubricating grease (sodium soap fat)	●
Methyl alcohol	○
Methyl alcohol/Benzine 15-85	●
Methyl ethyl ketone	○
Methylene chloride	–

Chemical	Resistance
Mineral oil	●
n-Heptane	●
n-Methyl-2-pyrrolidone	–
Nitric acid 20%	–
Petrol, regular	●
Petrol, super	●
Potash lye 1 N	○
Sea water	●
Soda lye 1 N	○
Sodium chloride solution, conc.	●
Sodium soap fat	●
Sodium soap fat + 20% water	○
Sulphuric acid 20%	○
Tetrahydrofuran	–
Toluene	–
Trichloroethylene	–
Water	●

Chemical resistance at room temperature

Symbols

- = good resistance
- = limited resistance; slight weight and dimensional changes after a certain period of time
- = no resistance

Splicing procedure/ on-site fitting

Siegling Proposition timing belts are made endless with a meander splice.

Although with this splice approximately 50% of the tensile strength of helically wound endless timing belts is achieved, such belts should not be used as power transmission belts.

Timing belts prepared for the meander splice can be hot-pressed endless quickly and easily on-site with our heating devices. This process makes time-consuming fitting work on the machine unnecessary. (Equipment data sheet ref. no. 566 and instructions ref. no. 487 available on request.)

The SMX-HP 150/120-PP and SMX-HP 150/60-PP heating presses can be used (with the corresponding splice guide) for all timing belts of all widths.

A handy heating press for smaller timing belt sizes and a punch-cutter for preparing the splice are currently in the developmental phase.

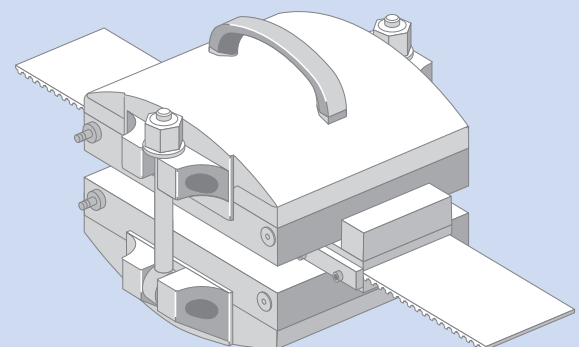
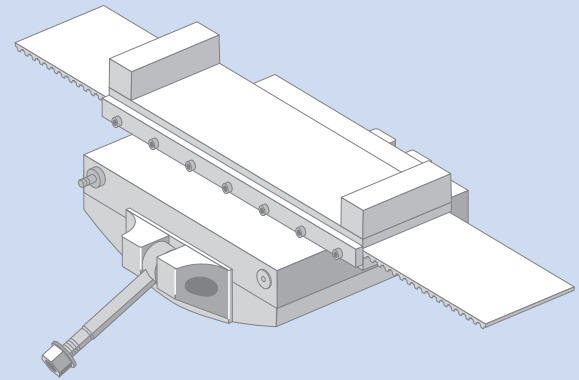
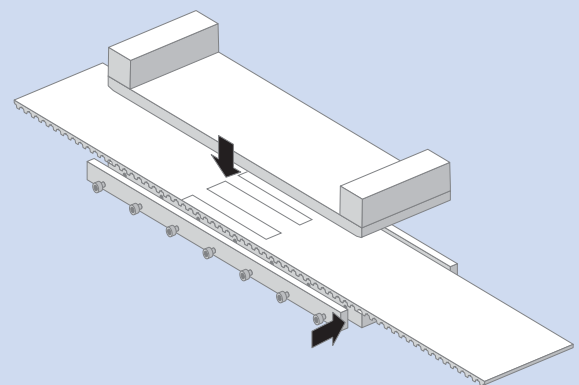
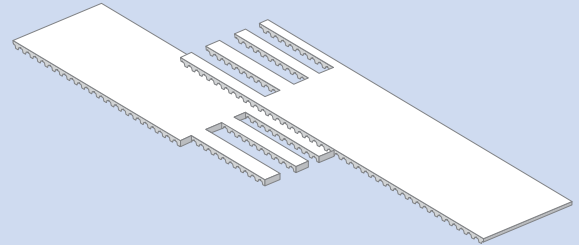

Siegling – total belting solutions

Committed staff, quality-orientated organisation and production processes ensure the constantly high standards of our products and services. The Forbo Siegling Quality Management System is certified in accordance with DIN EN ISO 9001:2000.

In addition to product quality, environmental protection is an important corporate goal. Early on we also introduced an environmental management system, certified in accordance with ISO 14001.

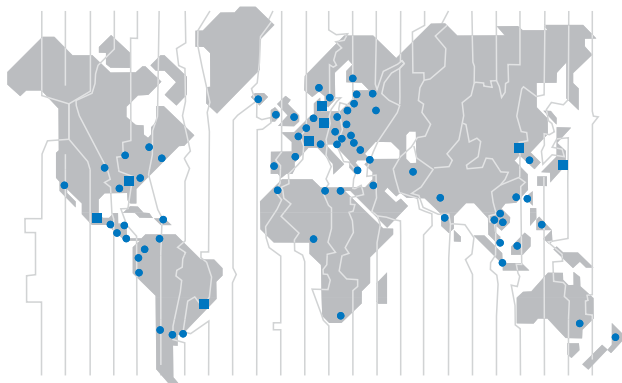

Forbo Siegling Service – anytime, anywhere

In the company group, Forbo Siegling employs more than 2000 people worldwide. Our production facilities are located in eight countries; you can find companies and agencies with stock and workshops in more than 50 countries. Forbo Siegling service centres provide qualified assistance at more than 300 locations throughout the world.